

**Connections:** NPT – Socket Weld – Other  
**Options:** Handwheel, Bronze, 'T' Bar

**Pressures:** 55 MPa  
 Working: 40 MPa @ 100°C  
 7 MPa @ 220°C

**Services:** Instrumentation &  
 Hydraulic Medias  
 Steam: 7000 kPa @ 400°C – BC891

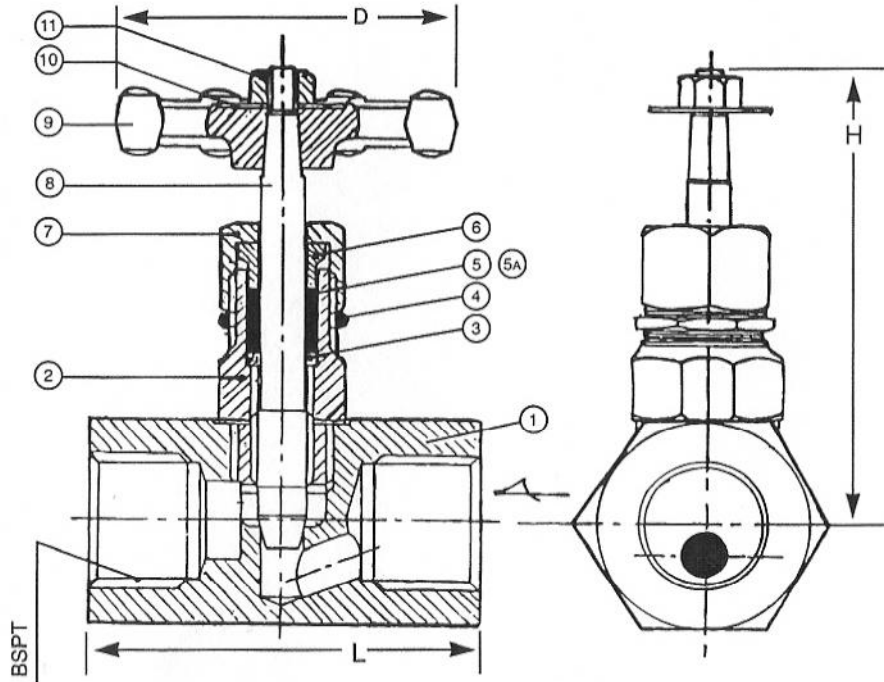

**Dimensions**

Size mm	8	10	15	20	25	32	40	50	65	80	100
L	51	51	77	82	95	127	127	TBA	•	•	•
H	77	77	77	110	110	190	190	TBA	•	•	•
D	65	65	65	90	90	150	150	TBA	•	•	•
Wt/kgs	0.4	0.4	0.6	1.2	1.5	4.0	4.0	TBA	•	•	•

Sizes: 32-40-50mm  
 Square Body

Cv – Flow Data  
 Refer  
 Drawing #112-113BC

ITEM	DESCRIPTION	MAT'L	STANDARD
11	HANDWHEEL NUT	STAINLESS BRASS	AISI304
10	NAMEPLATE	ALUMINIUM	
9	HANDWHEEL	ZINC ALUM	AS1874
8	SPINDLE	STAINLESS STEEL	ASTM A276 AISI316
7	GLAND NUT	STAINLESS STEEL	ASTM A276 AISI316
6	GLAND	STAINLESS STEEL	ASTM A276 AISI316
5A	GLAND PACKING	GRAPHOIL	
5	GLAND PACKING	PTFE	AS1198
4	LOCK NUT	STAINLESS STEEL	ASTM A276 AISI304
3	SEAL RING	STAINLESS STEEL	ASTM A276 AISI316
2	COVER – BONNET	STAINLESS STEEL	ASTM A276 AISI316
1	BODY	STAINLESS STEEL	ASTM A276 AISI316

**PVA PROMET VALVES AUSTRALIA**  
 1A Green Road Woodville West SA 5011  
 www.prometvalves.com promet@prometvalves.com  
 T: 08 8268 1777 ABN 47096 425 697 F: 08 8268 1711

FIG No **BC892** STAINLESS STEEL  
 NEEDLE VALVE PN